

HV CLASS 3

LSK 8 Ver.1

Small profile. Big performance.

- ⊕ Water proof sealed connection system
- ⊕ HVIL integration
- ⊕ Touch Protection
- ⊕ Multiple codings
- ⊕ Header includes wire and tabs solution



APPLICATIONS

- Electric steering and breaking
- E-Motor
- HV-Battery
- HV climate compressor
- Inverter
- On-Board Charger (OBC)
- And other devices

FEATURES



Current Carrying Capacity
105 A continuous
@ 80 °C / 16 mm²



EMI Shielding Class
100 kHz 300MHz
< 10 mΩ



Voltage Range
600 V @ 5500 m ASL



Sealing Protection
IP67, IP6K9K



Temperature
-40 °C to 125 °C



Touch Protection
IPxxB



Cable Cross-Section
4 mm², 6 mm² and
10 mm²



Validation acc. to
B21 70 50 E

we **connect**

Experience how we connect the global automotive industry with high performance connector systems.

www.kostal-kontakt-systeme.com



DIMENSIONS

Receptacle Housing

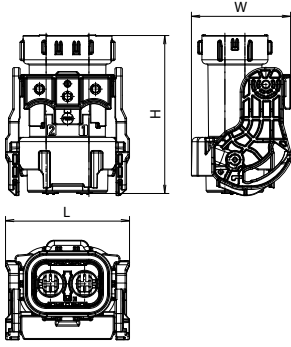

Tab Header

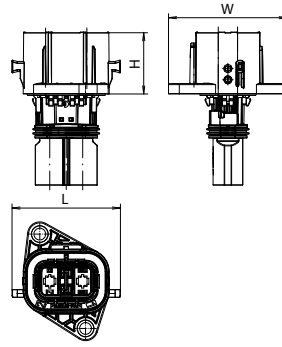

Tab Header

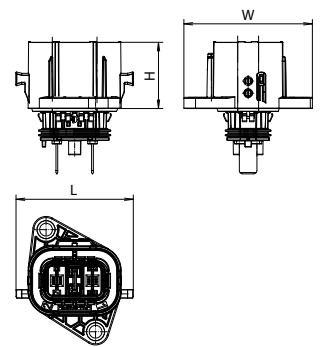

TECHNICAL DATA

Receptacle Housing with CPA

Tab Header

Cavities	PN Code A	Dimensions L x H x W (mm)	PN Code A	Dimensions L x H x W (mm)	Other Codings
2 + 2	10527202	58.8 x 74.9 x 47.01	10527221	53.3 x 30.1 x 58.4	A - D
			10527234	53.3 x 30.1 x 58.4	A - D



LSK 8

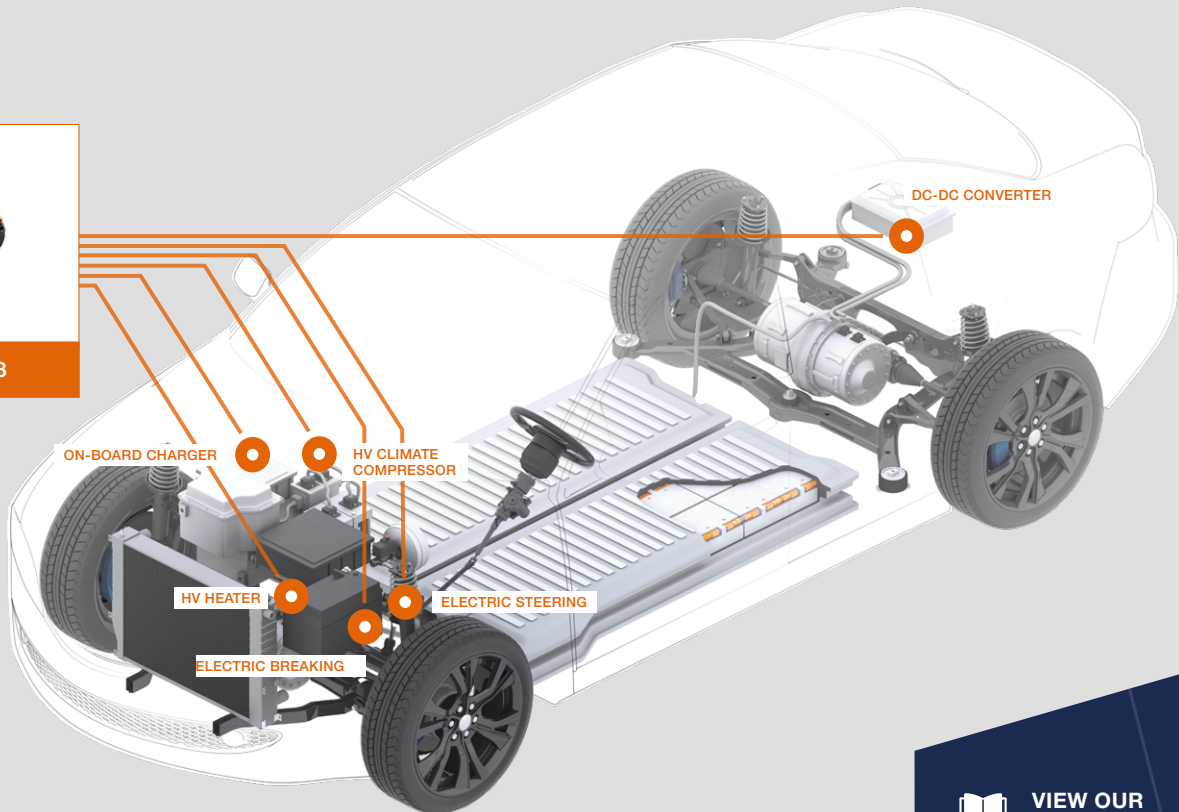

COMPATIBLE WITH



LSK 8



VIEW OUR
PRODUCT CATALOGUE



CONTACT US:
kks_portfolio@kostal.com