

# HV CLASS 3 LSK 8 Ver. 2

Waterproof sealed connection system

- ⊕ Touch protection
- ⊕ Multiple codings
- ⊕ With CPA
- ⊕ V0 Material
- ⊕ HVIL optional

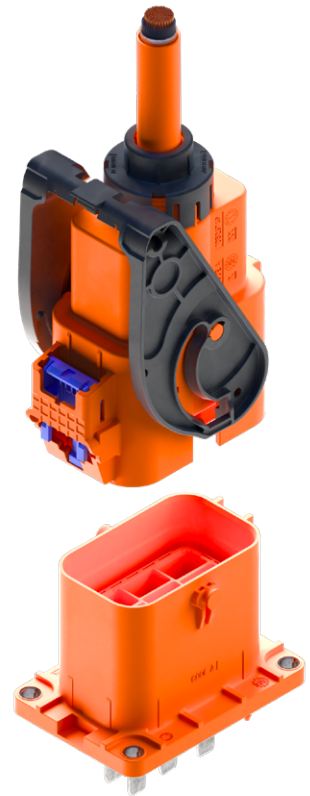

## APPLICATIONS

- On-Board Charger (OBC)
- And other devices

## FEATURES



**Current Carrying Capacity**  
65 A continuous  
@ 80 °C / 6 mm<sup>2</sup>



**Sealing Protection**  
IP67, IP6K9K



**Voltage Range**  
600 V @ 4000 m ASL



**EMI Shielding Class**  
40 dB (0.5 - 1.7 MHz)  
30 dB (70 - 108 MHz)



**Temperature**  
-40 °C to 140 °C



**Touch Protection**  
IPxxB



**Cable Cross-Section**  
6 mm<sup>2</sup> (ES91110-14)



**Validation acc. to**  
LV-215  
ES91500-20

we **connect**

Experience how we connect the global automotive industry with high performance connector systems.

[www.kostal-kontakt-systeme.com](http://www.kostal-kontakt-systeme.com)



## DIMENSIONS

Receptacle Housing

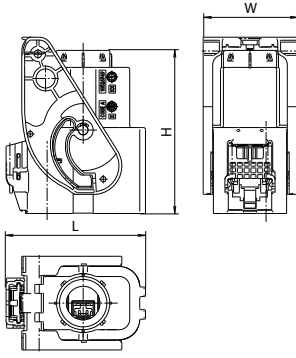

Tab Header

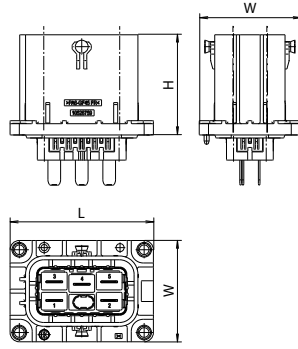

## TECHNICAL DATA

Receptacle Housing with CPA

Tab Header

Cavities	PN Code A	Dimensions L x H x W (mm)	PN Code A	Dimensions L x H x W (mm)
5	10526748	73 x 85.4 x 49.05	10526758	71.25 x 49.8 x 50.35



LSK 8

ON-BOARD CHARGER

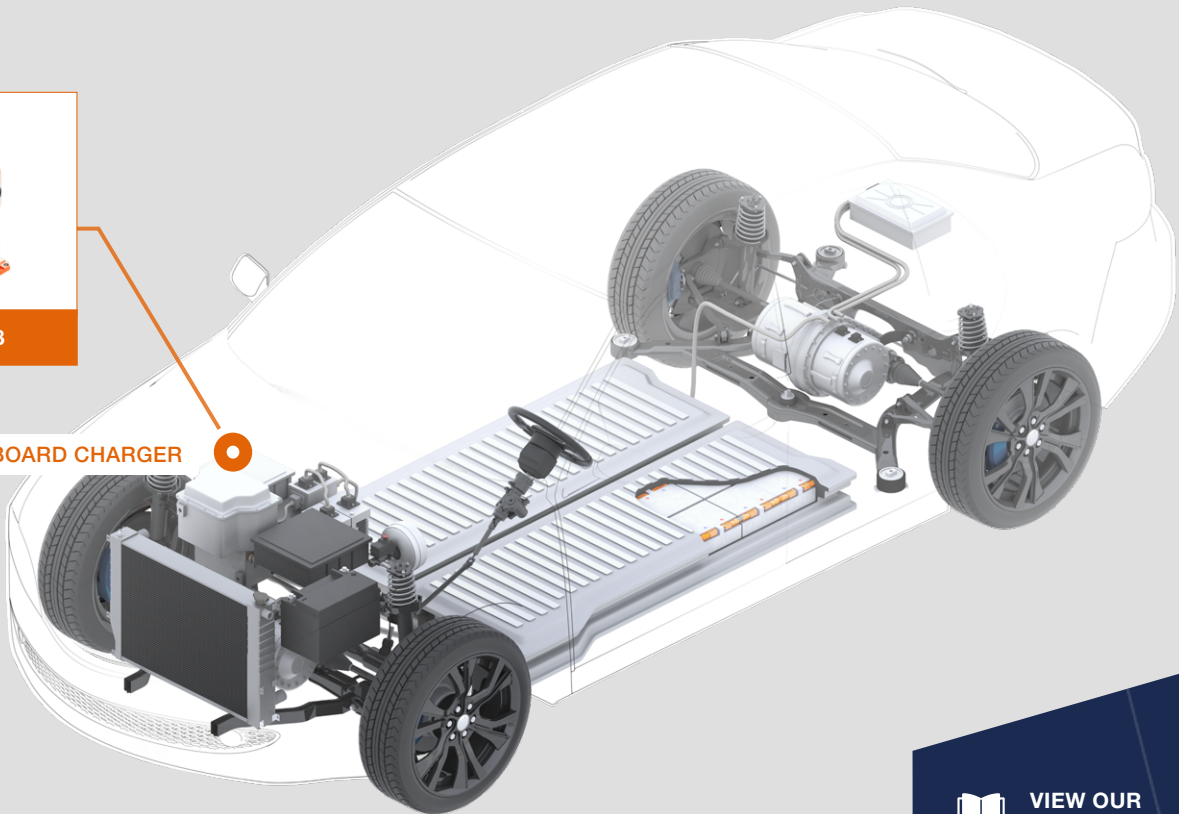

## COMPATIBLE WITH



LSK 8



VIEW OUR  
PRODUCT CATALOGUE



CONTACT US:  
kks\_portfolio@kostal.com