

HV CLASS 3 LSK 8 & SLK 5,8

Made for On-Board Chargers

- ⊕ HVIL integration
- ⊕ Touch Protection
- ⊕ Multiple codings
- ⊕ With CPA
- ⊕ V0 Material

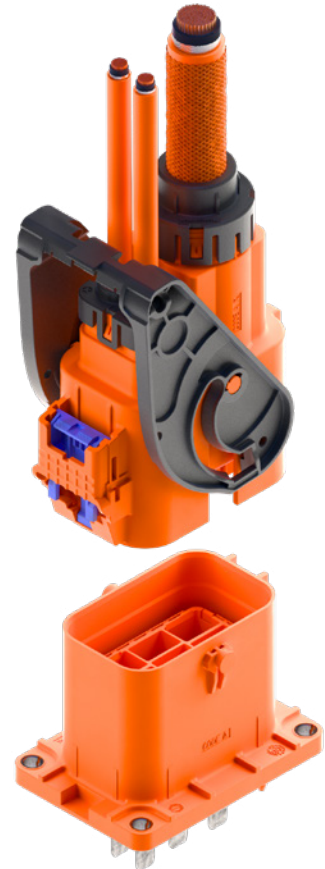

APPLICATIONS

- On-Board Charger (OBC)
- And other devices

FEATURES



Current Carrying Capacity
AC 65 A @
80 °C continuous



Sealing Protection
IP67, IP6K9K



Voltage Range
600 V @ 4000 m ASL



Touch Protection
IPxxB / IPxxD



Temperature
-40 °C to 140 °C



Validation acc. to
ES91500-20



EMI Shielding Class
≥ 40 dB (510kHz~1710kHz)
≥ 30 dB (70MHz~108MHz)

we **connect**

Experience how we connect the global automotive industry with high performance connector systems.

www.kostal-kontakt-systeme.com



DIMENSIONS

Receptacle Housing

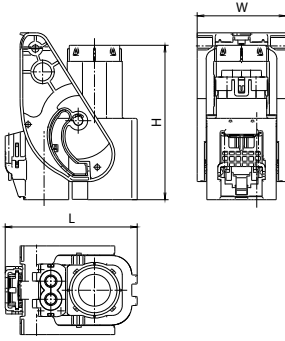

Tab Header

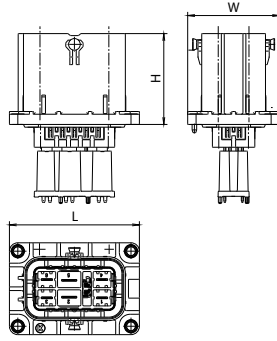

TECHNICAL DATA

Receptacle Housing

Tab Header

Cavities	PN Code A	Dimensions L x H x W (mm)	PN Code A	Dimensions L x H x W (mm)
6 + 2	10531101	73 x 85.4 x 49.05	10531191+10543399	71.25 x 49.8 x 50.35



LSK 8 & SLK 5,8

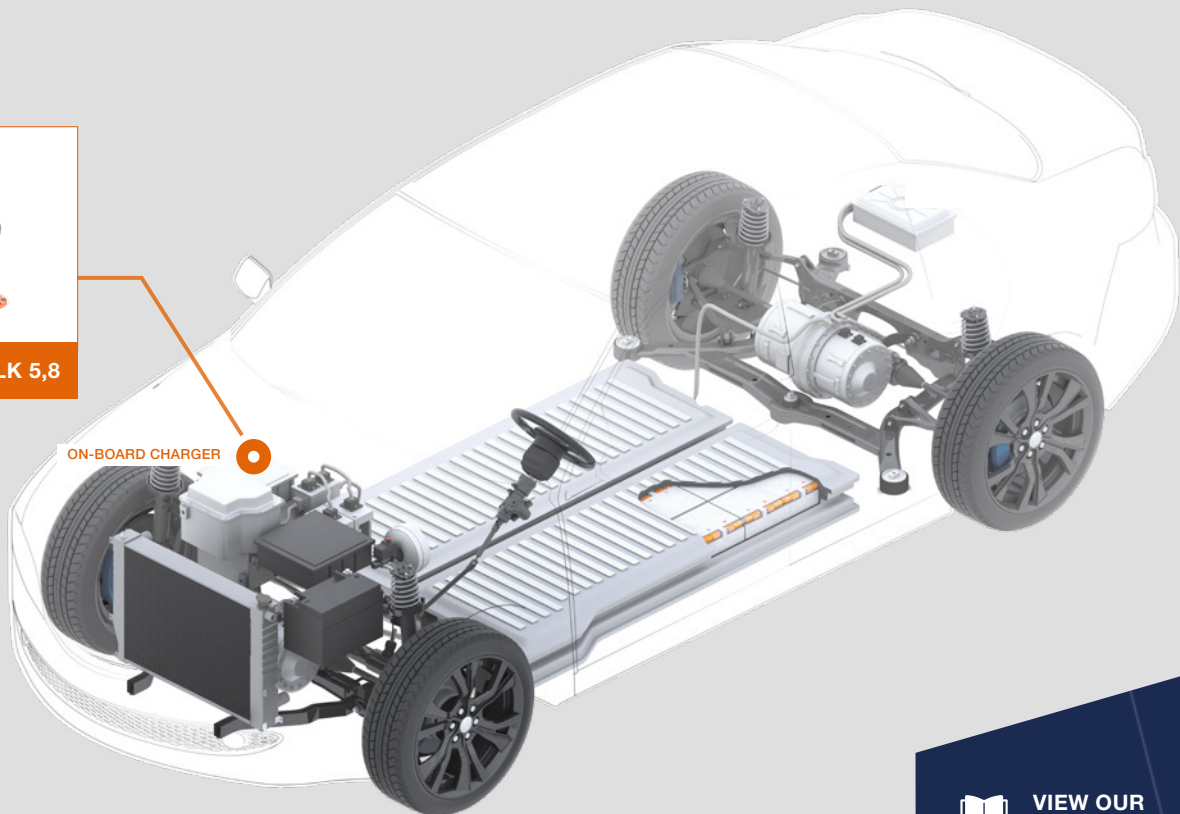

ON-BOARD CHARGER



COMPATIBLE WITH



LSK 8



SLK 5,8



VIEW OUR
PRODUCT CATALOGUE



CONTACT US:
kks_portfolio@kostal.com