

HV CLASS 3 LSK 8 & SLK 5,8

Made for On-Board Chargers

- ⊕ HVIL integration (on demand)
- ⊕ Touch Protection
- ⊕ Multiple codings
- ⊕ With CPA
- ⊕ V0 Material

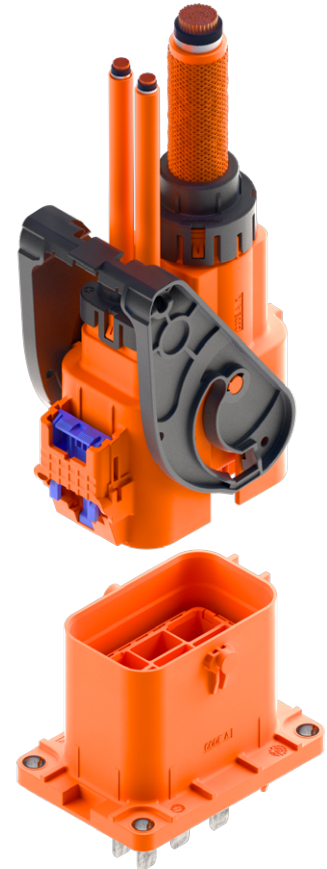

APPLICATIONS

- On-Board Charger (OBC)
- And other devices

FEATURES



Current Carrying Capacity
AC 65 A @
80 °C continuous



Sealing Protection
IP67, IP6K9K



Voltage Range
600 V @ 4000 m ASL



Touch Protection
IPxxB / IPxxD



Temperature
-40 °C to 140 °C



Validation acc. to
ES91500-20



EMI Shielding Class
≥ 40 dB (510kHz~1710kHz)
≥ 30 dB (70MHz~108MHz)

we **C**onnect

Experience how we connect the global automotive industry with high performance connector systems.

www.kostal-kontakt-systeme.com

DIMENSIONS

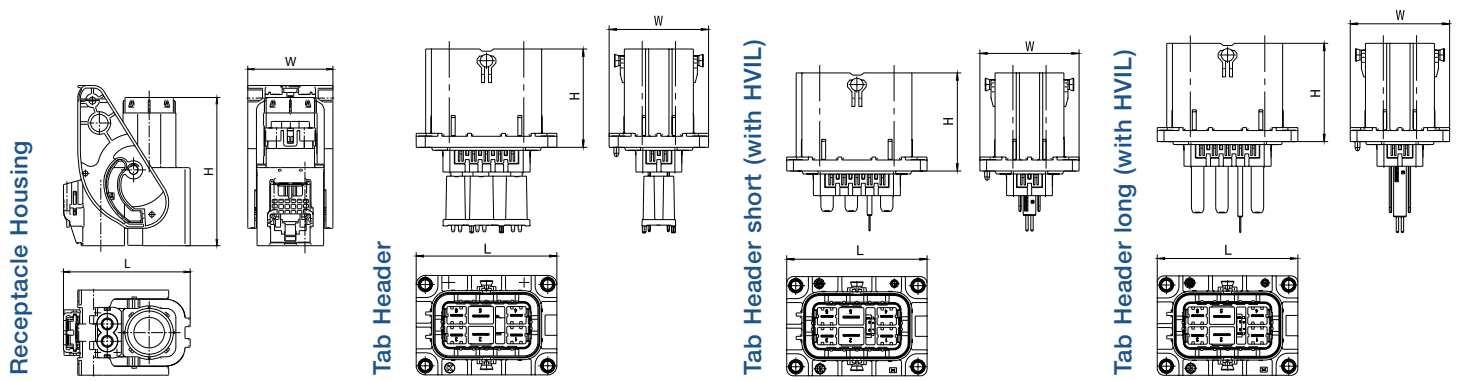

TECHNICAL DATA

Receptacle Housing

Cavities	PN Code A	Dimensions L x H x W (mm)
6	10531101	73 x 85.4 x 49.05
6+2 short	10531101	71.25 x 49.8 x 50.35
6+2 long	10531101	71.25 x 49.8 x 50.35

Tab Header

PN Code A	Dimensions L x H x W (mm)
10531191+10543399	71.25 x 49.8 x 50.35
12184826	71.25 x 49.8 x 50.35
12185832	71.25 x 49.8 x 50.35

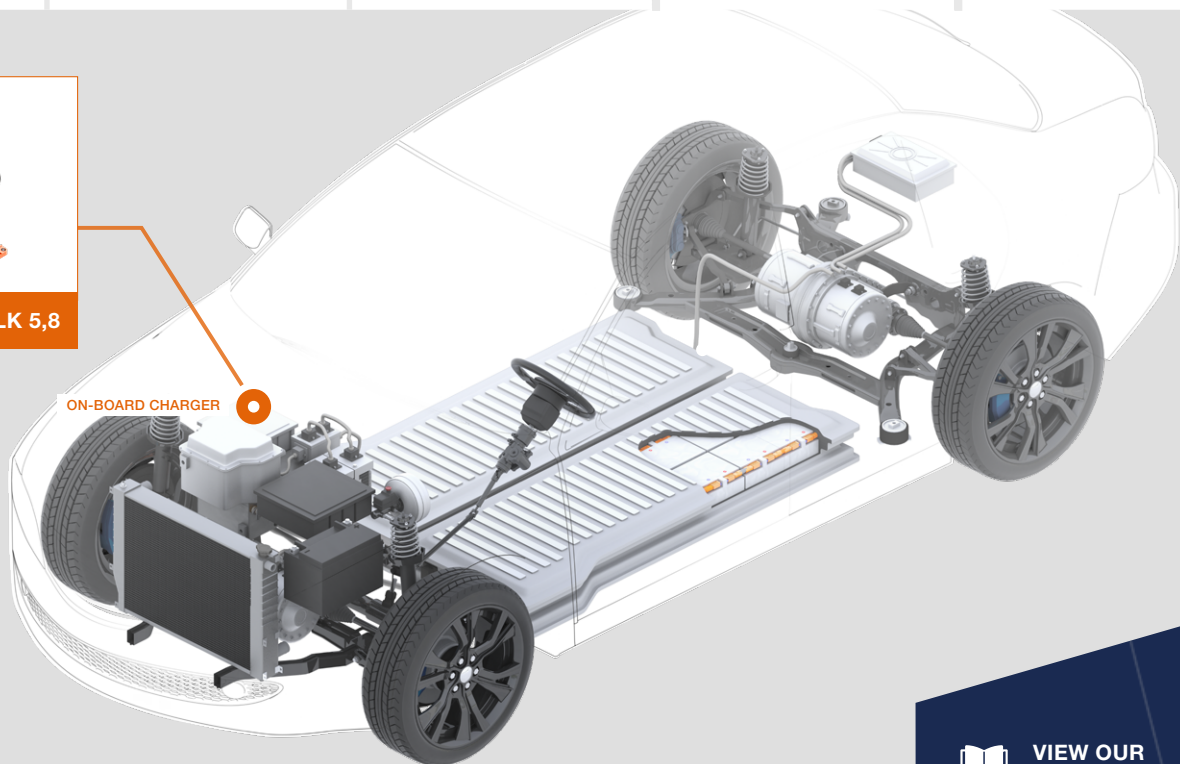

COMPATIBLE WITH



VIEW OUR
PRODUCT CATALOGUE



CONTACT US:
kks_portfolio@kostal.com