

HV CLASS 4

KS 22

Smallest in class. Easy assembly.

- ⊕ Water proof sealed connection system
- ⊕ HVIL integration
- ⊕ Touch protection
- ⊕ Tab-Header attachable with single screw in sealed area
- ⊕ Various cable types validated

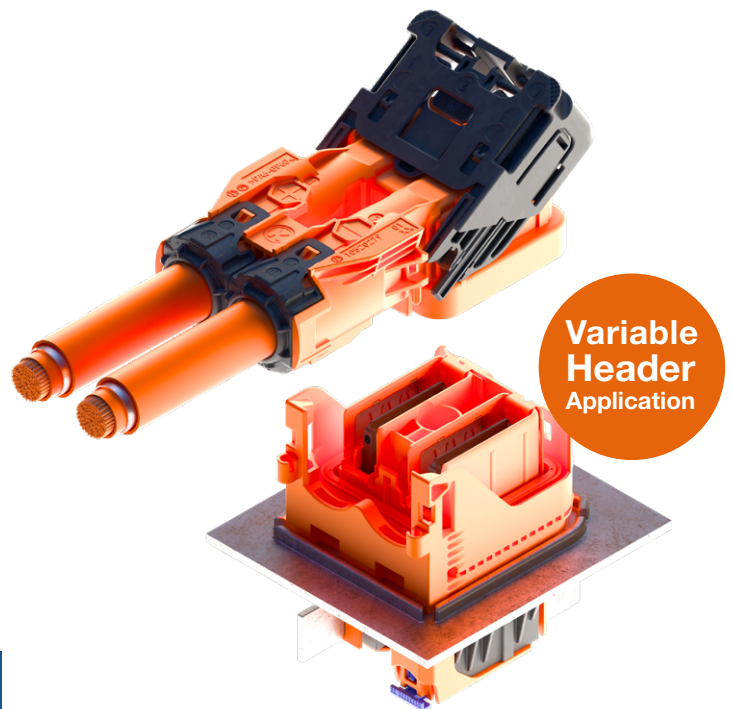

APPLICATIONS

- High voltage/high-current modules
- Inverter, battery, DC-DC converter
- And other devices

FEATURES



Current Carrying Capacity
252 A continuous
@ 80 °C / 50 mm²



EMI Shielding Class
< -50dB (1-300 MHz)



Voltage Range
1000 V at 5500 m ASL
(max. 3300 V DC)



Sealing Protection
IP67, IP6K9K



Temperature
-40 °C to 140 °C



Touch Protection
IPxxB / IPxxD



Cable Cross-Section
16 - 50 mm²,
Cu and Al wires



Validation acc. to
LV-215
B21 70 50
USCAR

Experience how we connect the global automotive industry with high performance connector systems.

www.kostal-kontakt-systeme.com



DIMENSIONS

Receptacle Housing

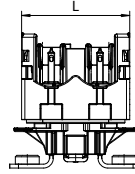
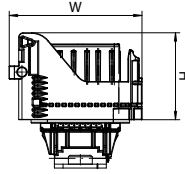
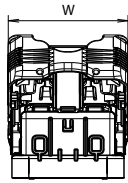
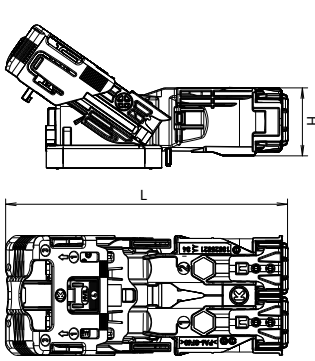

Tab Header

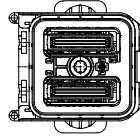

TECHNICAL DATA

Receptacle Housing with CPA

Tab Header

Cavities	PN Code A	Dimensions L x H x W (mm)	PN Code A	Dimensions L x H x W (mm)
2	on request*	118 x 33.5 x 50	on request*	50 x 40.2 x 61.4

VARIABLE HEADER OPTIONS

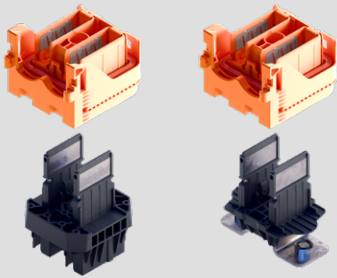

KS 22 CLASS 4

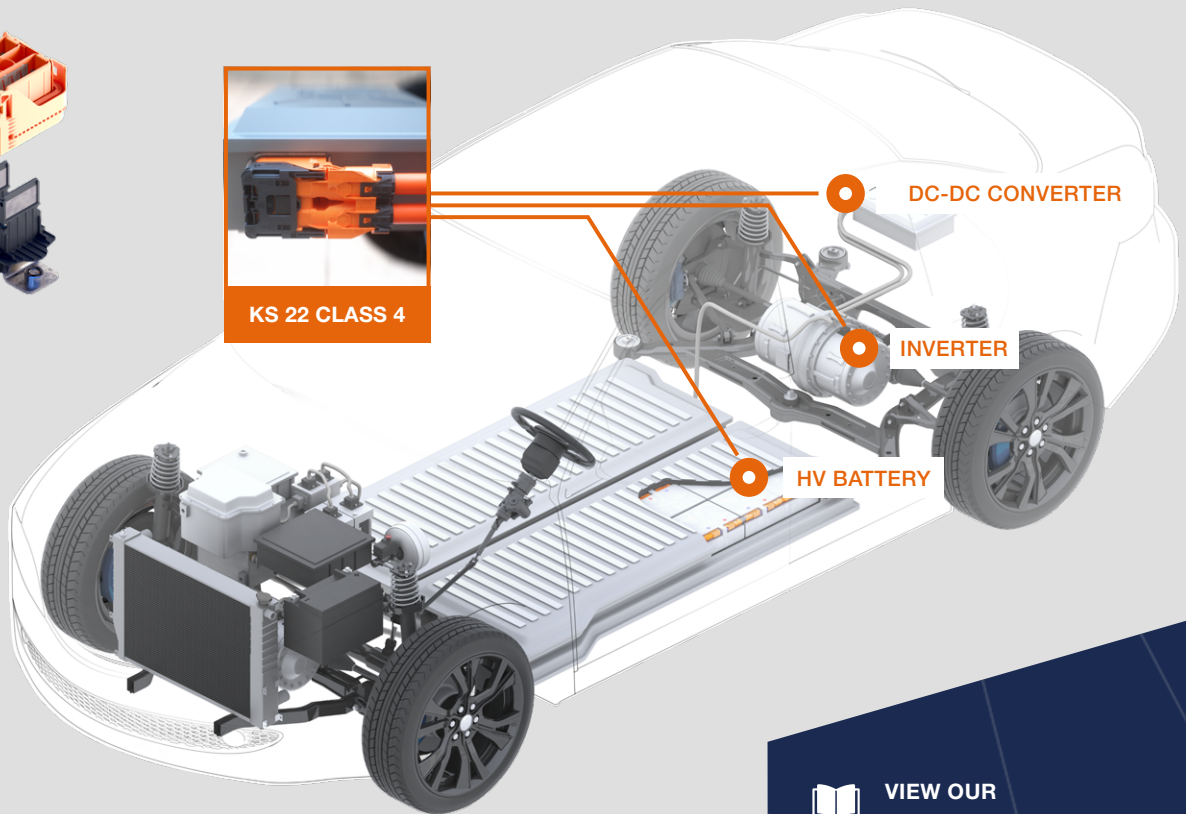

*Due to the wide range of variants, please contact us for detailed part number information.



COMPATIBLE WITH



Terminal KT 22



VIEW OUR
PRODUCT CATALOGUE



CONTACT US:
kks_portfolio@kostal.com