

## LOW VOLTAGE CONNECTOR

# MK 0,5 Flex System

Designed for E-mobility  
and flexible automation.

- ⊕ Modular design, optimized for flex circuit (Al / Cu) processing and application performance
- ⊕ Design for high speed laser welding processes (FPC / FFC)
- ⊕ Side CPA reduces overall packaging height in module
- ⊕ Meets USCAR 2 / USCAR 25

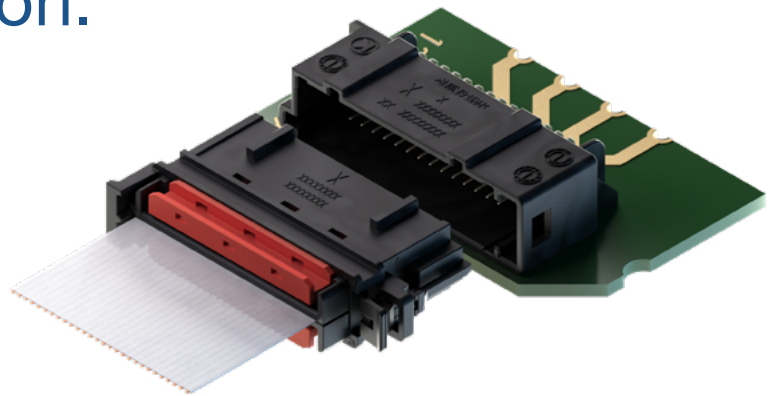

## APPLICATIONS

- Battery module systems
- Infotainment - display systems
- Integrated seat and door modules
- Headliner systems
- Lighting systems

## FEATURES



**Current Carrying Capacity**  
3 A continuous  
@ 80 °C



**Pitch**  
2.2 mm



**Temperature**  
Flex Foil  
-40 °C to 105 °C



**Validation acc. to**  
USCAR 2  
USCAR 25



**Cable**  
Flex Foil  
0.8 x 0.125 mm

Experience how we connect  
the global automotive industry  
with high performance  
connector systems.

[www.kostal-kontakt-systeme.com](http://www.kostal-kontakt-systeme.com)



## DIMENSIONS

Receptacle Housing

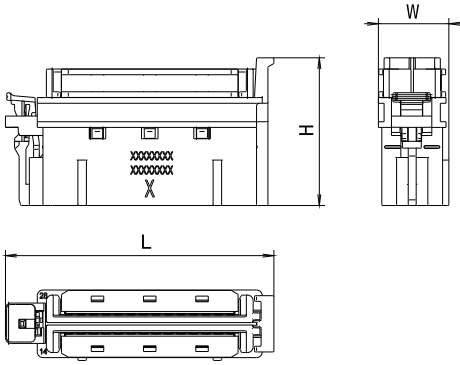

Tab Header

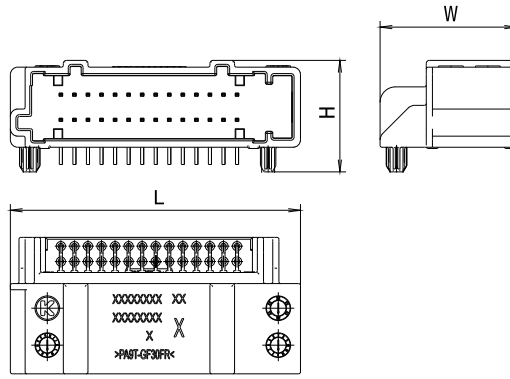

## TECHNICAL DATA

### Receptacle Housing

Cavities	PN Code A	Dimensions L x H x W (mm)
28	12158750	47.25 x 26 x 12.4

### Tab Header

PN Code A	Dimensions L x H x W (mm)	Other Codings
10544035	47.1 x 18.1 x 22.15	B

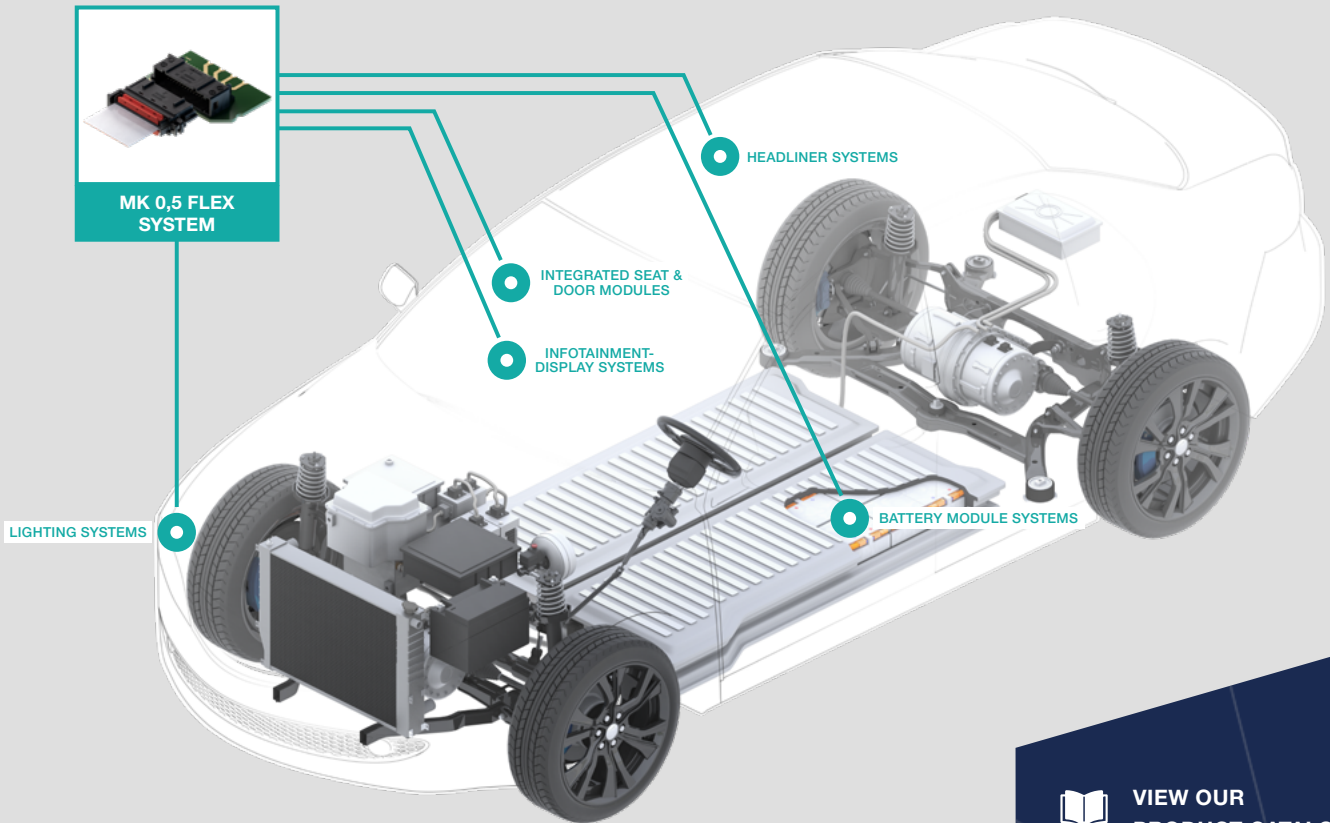

## COMPATIBLE WITH



Terminal MK 0,5



VIEW OUR PRODUCT CATALOGUE



CONTACT US:  
kks\_portfolio@kostal.com